

# CityCat 5006 Euro 6 (118 kW) Specifications

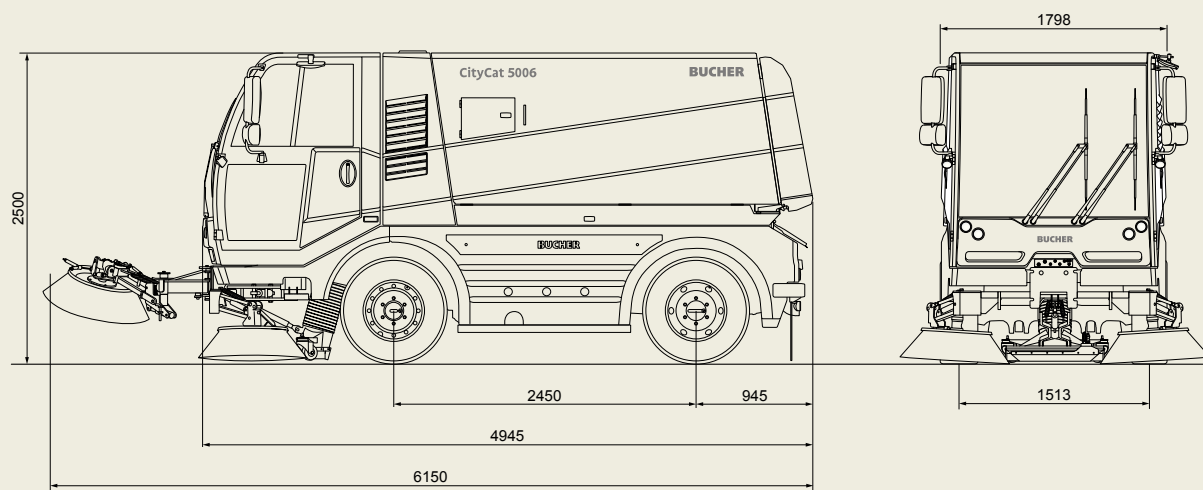

## Dimensions

Length	4945 mm
Width	1798 mm
Height	2500 mm
Wheelbase	2450 mm
Track	1513 mm
Max. Cleaning width Type SL	2533 mm
Max. Cleaning width Type XL	3520 mm
Turning circle	5900 mm

## Tyres

265 / 70 R 19.5 140 / 138M

## Noise level cab

63 dB(A)

## Driving Performance

Working speed	0-20 km/h
Travelling speed	0-50 km/h
Climbing ability	30%

## Chassis

Bucher fabricated ladder frame chassis with "C" Rail construction.

GVW	10500 kg
Empty weight	5500 kg
Payload	5000 kg

## Engine

FPT, Iveco Diesel engine Euro 6

	Typ NEF 45 ENT 6
Engine Displacement	4485 cm <sup>3</sup>
Output	118 kW
Torque	580 Nm
Fuel tank	110 l
AdBlue tank	30 l
Electrical system	24 V

CityCat 5006: service package in the compact class

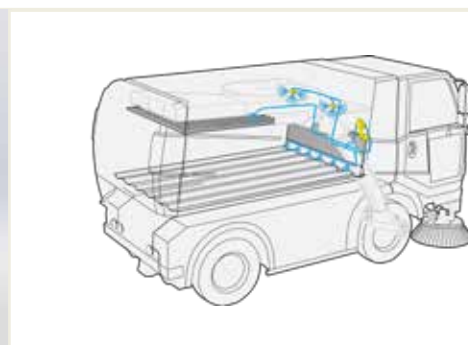

**Low-emission Engine Euro 6** The smooth-running, high-torque Iveco Euro 6 diesel engine with extremely low fuel consumption and emission levels allows exceptionally reliable and economical operation.

**Large 7-inch central display** Thanks to the diagnostics system, the 7-inch central display provides easy access to all relevant machine data such as total running time and working hours, operational and road travel, fuel consumption etc.

**Easy Clean System** The operator simply activates the EasyClean self-cleaning function. The blower, filter screen, dirty water tank, side walls and other difficult to reach pockets of dirt are then sprayed by the cleaning nozzles. The machine is perfectly clean within a couple of minutes.

# CityCat 5006 Euro 6 (118 kW) Specifications

**Steering** Hydrostatic controlled four wheel steering.

**Axles** Drive-axle at the rear with differential and planetary hub reduction. Running axle at the front.

**Hydraulic** The latest electronic control concept makes it possible to control the diesel engine in terms of optimal consumption and noise for a hydrostatic drive over the entire speed range. Without compromising on performance.

Diesel consumption and exhaust pollutant emissions have been greatly reduced thanks to the electronic control concept and the Euro 6 diesel engine. Valuable resources and the entire vehicle system are protected. Test drives have resulted in diesel savings of 30% as well as a 20% noise reduction when passing by in road travel mode. On top of that, the positive effect can also be seen in the operating costs.

**Brakes** Hydraulic, dual-circuit high performance brake system with double callipers on each side on front axis and single calliper on rear axis. Manually operated parking brake, acting hydraulically on additional brakes disc ahead of differential.

**Driver's cab** Comfortable, hydro bearing suspension, soundproofed cab. Windscreen made of heat-insulating, curved, low-reflection safety glass. 2 sliding windows in each door. Multi-speed heating fan. Sun visor. Windscreen wiper/washer system Air-sprung driver's seat and sprung passenger's seat, each individually adjustable. Steering column can be adjusted in both the angle and height. Clearly and ergonomically arranged operating and monitoring instruments with a 7" colour display. Visual and acoustic alarm for temperature and liquid level monitoring. Visual diagnostic system with intuitive design.

**Pick-up system** Pick-up principle based on suction, with retracted, rust-proof suction nozzle in front of axis, can be hydraulically moved 400 mm laterally with the side brush. Hydraulic suction nozzle height adjustment. Stepless adjustable high-power suction fan.

**Hopper**  
Stainless steel hopper 5.6 m<sup>3</sup>  
hydraulic tipping and opening.  
Dumping height, low dumping 930 mm  
Dumping height, high dumping 1550 mm  
Dumping width 1700 mm  
Tipping angle 51°

**Water system**  
Fresh water tank ca. 880 l

2 Water pumps for water nozzles

**Brushes**  
2 side brushes left and right Ø 900 mm  
Variable speed adjustment 0-150 rpm  
Impact-proof brush suspension - impact protection

3rd front brush on Type XL for maximum cleaning width of 3520 mm, can be used left and right  
Variable speed adjustment 0-150 rpm

- Options**
- Air conditioning
  - High Dump
  - Water recirculation system
  - Wander hose
  - Weed brush
  - Hydraulic tilt of the side brushes
  - Water flushing bar
  - High pressure water system
  - EasyClean system
  - Gutter guard lifting gear
  - LED work light
  - Rear view and suction nozzle camera
  - Data capture

A range of optionals is available - Contact us for more information.

Subject to change without notice.

**Bucher Municipal AG**  
Murzlenstrasse 80  
CH-8166 Niederweningen  
Tel. +41 44 857 22 11  
Fax +41 44 857 24 10  
sweepers@buchermunicipal.com  
www.buchermunicipal.com/sweepers

simply great sweepers

Innovation • Competency • Reliability • Sustainability



Bucher Municipal  
E-Shop

